



All Flex Solutions – Water Conservation

Nile Timmerman

MnTAP Advisor: Laura Sevcik

Company Supervisors: Jon Gilligan



UNIVERSITY OF MINNESOTA

Driven to DiscoverSM

All Flex Solutions



Location: Northfield, MN

Size: 20,000 sq. feet, 135 employees

Products:

- Flexible Circuits
- Rigid Circuits
- Flexible Heaters

Industries:

- Aerospace, Defense, Computing, Medicine



Incentives to Change

Sustainability

- Single Pass Cooling

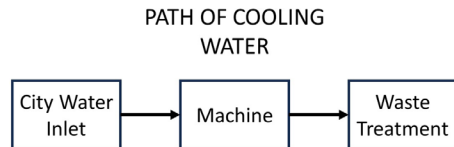

Incentives to Change

Sustainability

- **Single Pass Cooling**

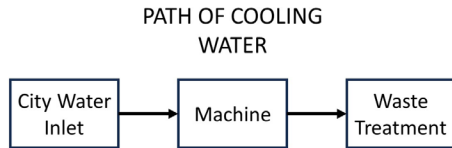

Current Usage

- **15,500,000 gallons per year (gpy)**
- **\$129,000 per year**

Incentives to Change

Sustainability

- **Single Pass Cooling**

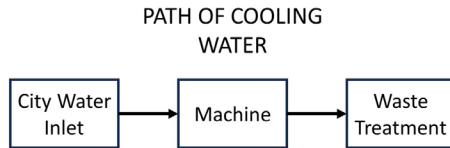

Current Usage

- **15,500,000 gallons per year (gpy)**
- **\$129,000 per year**

Expansion

- **New location opening in Bloomington**



Water Flow Measurement

- Measured 27 different lines with an ultrasonic flow meter
- Measured rinse and cooling lines



Usage Analysis and Water Map

- Wet Room – **98%** of site water usage
- Uses Reverse Osmosis (R.O.) water, Soft water, and City water
- R.O. water is most frequently used
- City Water is used primarily for non-contact cooling



Current Cooling Water Line

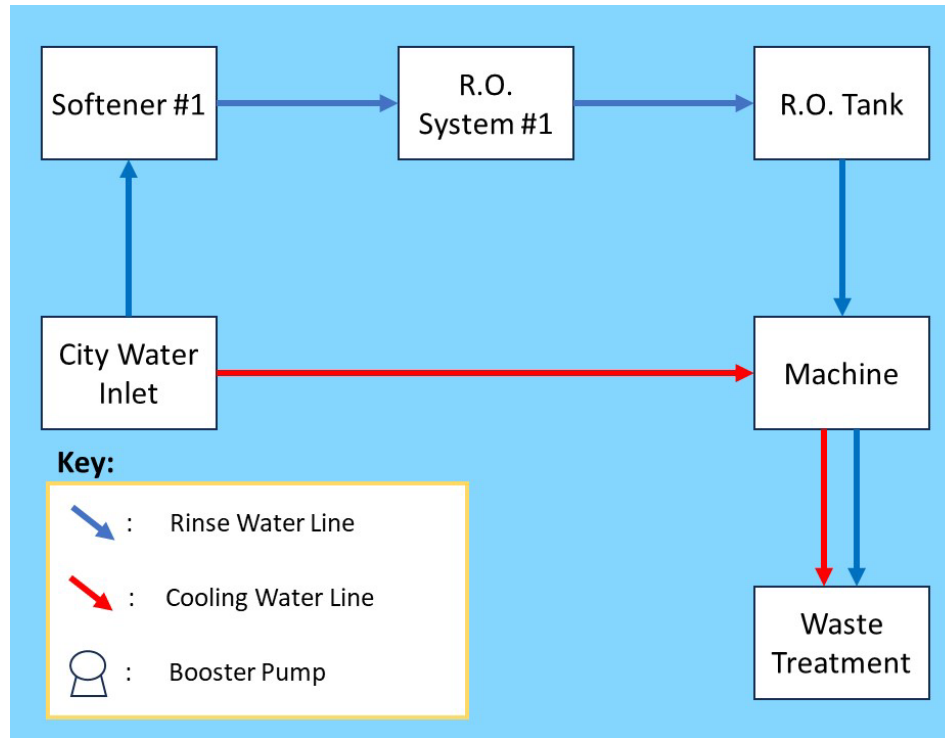

Cooling Water Recycle Line

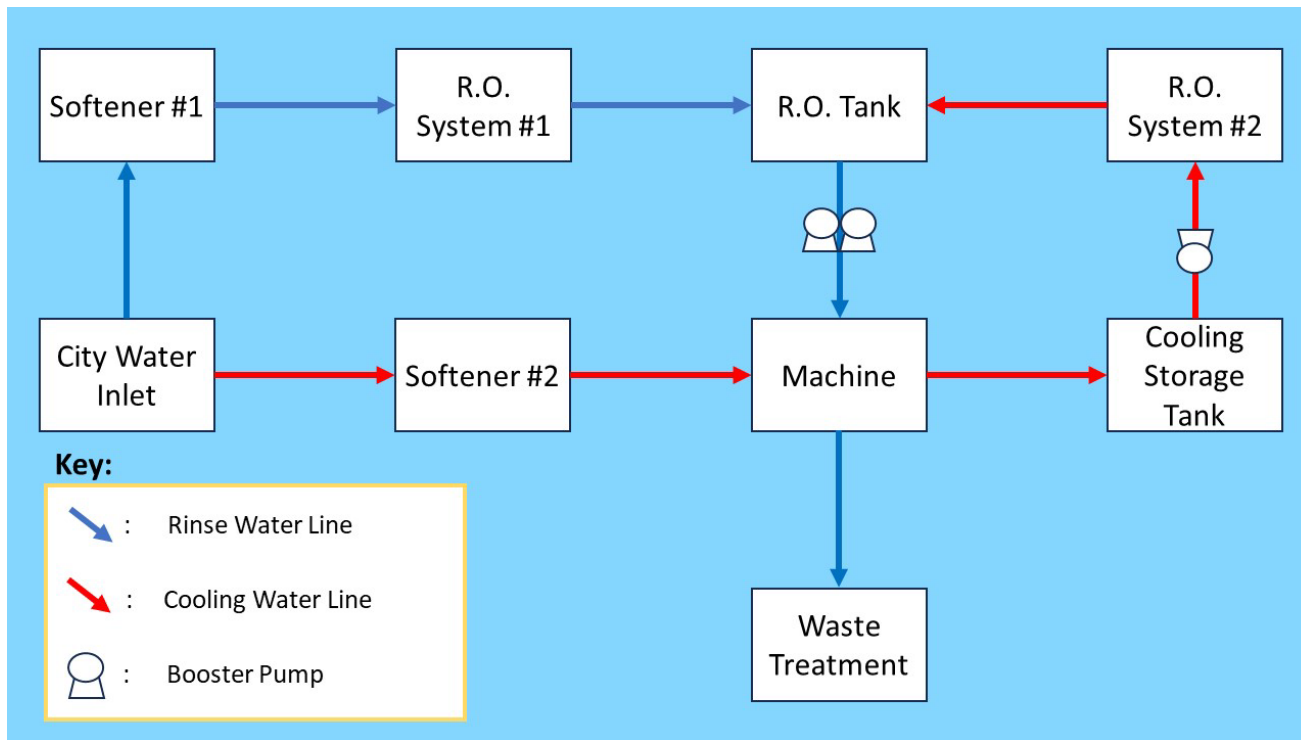

Cooling Water Recycling

Water Usage Reduction

- 3,300,000 gpy

Annual Savings

- \$27,000 per year

Payback Period

- 16 months

Effect of Recycle Line on Water Usage

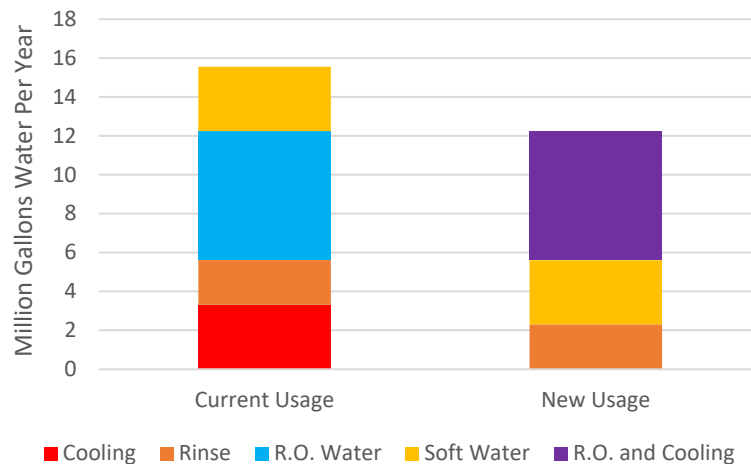

Solutions

Recommendation	Annual reduction	Total cost	Annual savings	Payback period	Status
Cooling Water Recycling	3,300,000 gpy	\$35,000	\$27,000	16 months	Planned
Add Flow Restrictors	1,100,000 gpy	\$200	\$9,500	8 days	Implementing

Personal Benefits

- Creative problem solving
- Thinking Feasibly
- Learned from engineers in different fields
- Developed familiarity with various analytical tools

