

St. Croix Forge

Amanda Spencer
Advisor: Karl DeWahl

Minnesota Technical Assistance Program

UNIVERSITY OF MINNESOTA

Introduction



Company Overview

- Steel Horseshoes



Company Overview

- Steel Horseshoes
 - Induction Heaters



Company Overview

- Steel Horseshoes
 - Induction Heaters
 - Cooling System



Company Overview

- Steel Horseshoes
 - Induction Heaters
 - Cooling System
 - Forge Press



Company Overview

- Steel Horseshoes
 - Induction Heaters
 - Cooling System
 - Forge Press
 - Warehouse



Incentives for Change

- Reduce energy use
 - 4,600,000 kWh
 - \$390,000
- Reduce material use

Energy Consumption

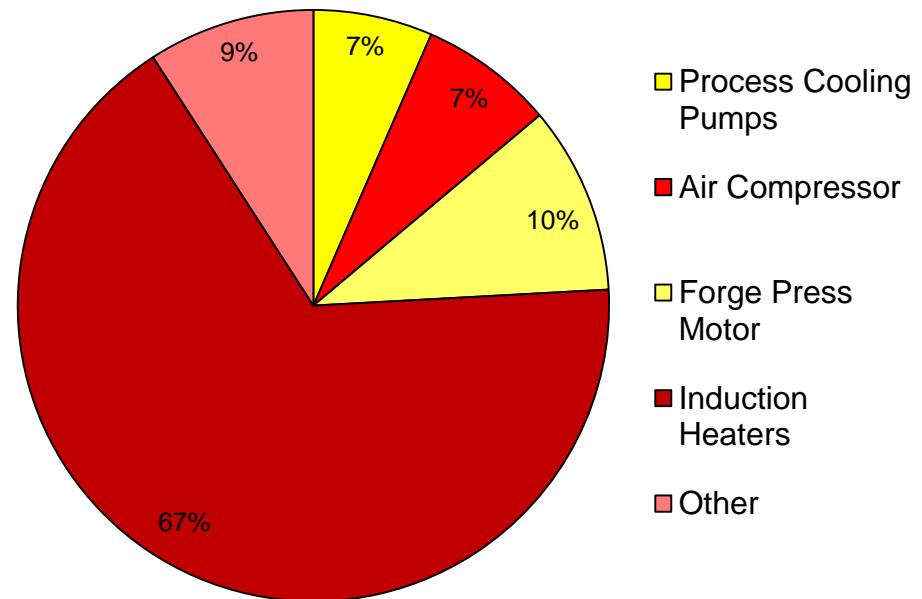

Project Overview

- Objectives



Project Overview

- Objectives
 - Process cooling



Project Overview

- Objectives
 - Process cooling
 - Grease application



Project Overview

- Objectives
 - Process cooling
 - Grease application
 - Etc.

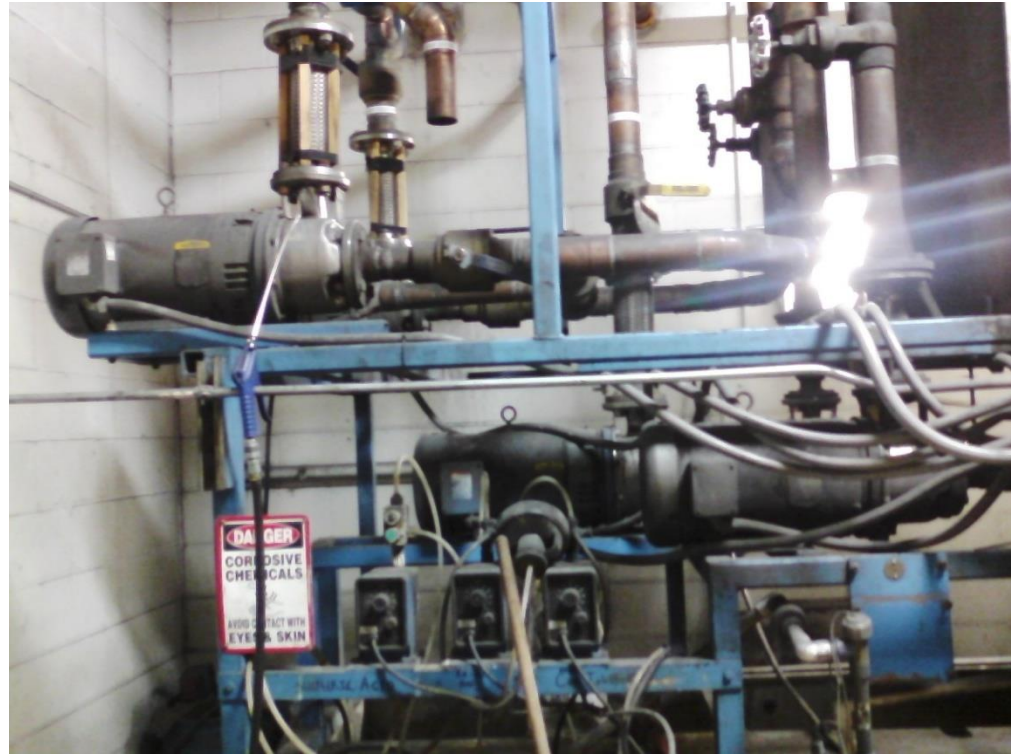

Process Cooling Circulation

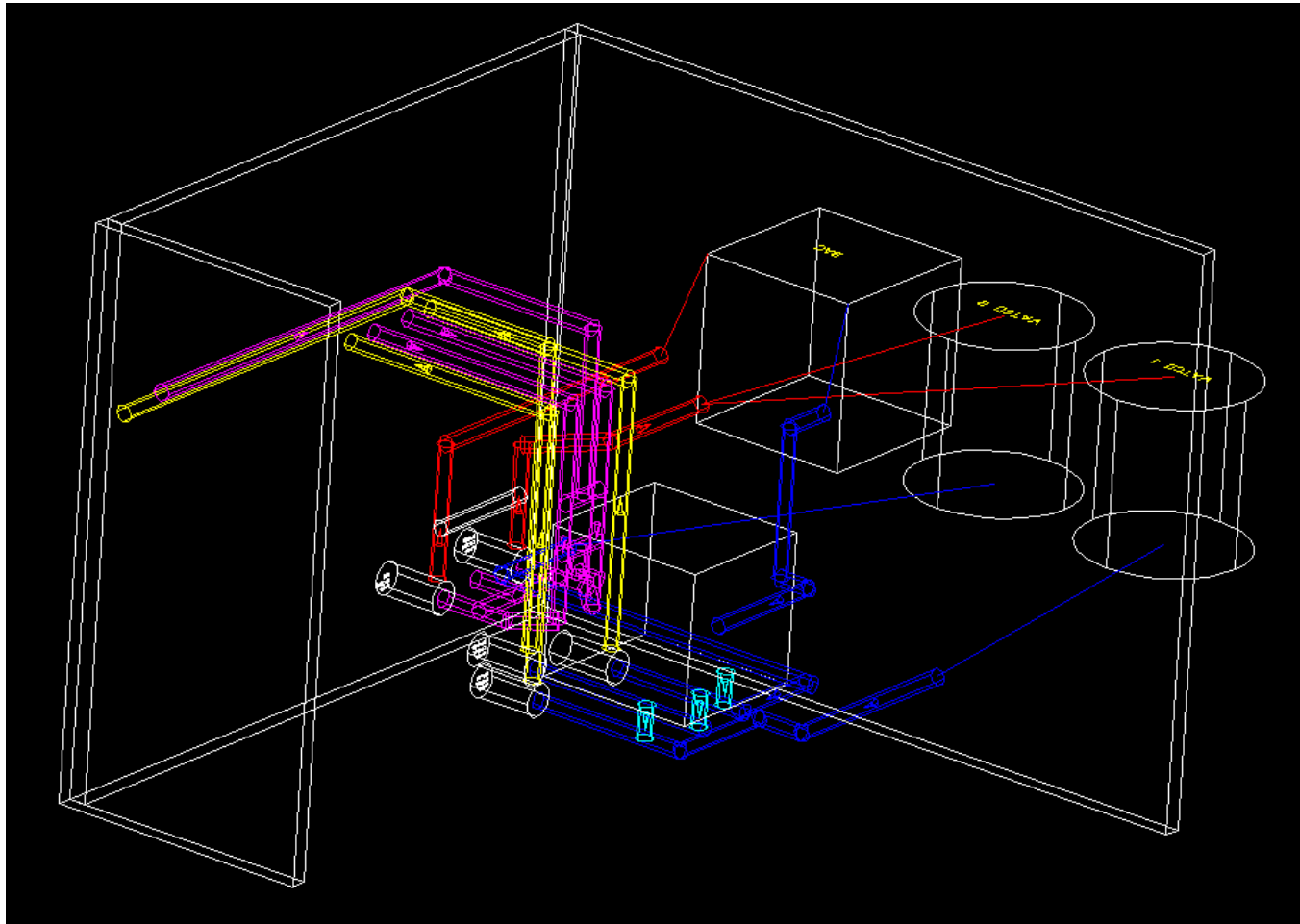

Process Cooling Circulation

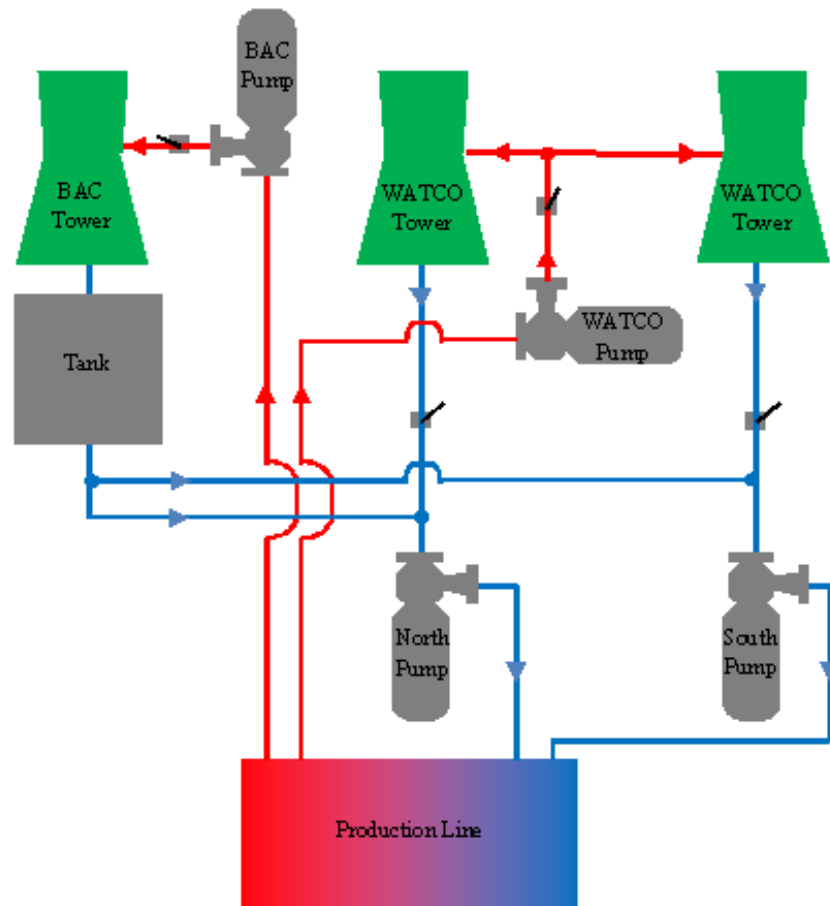

Process Cooling Circulation

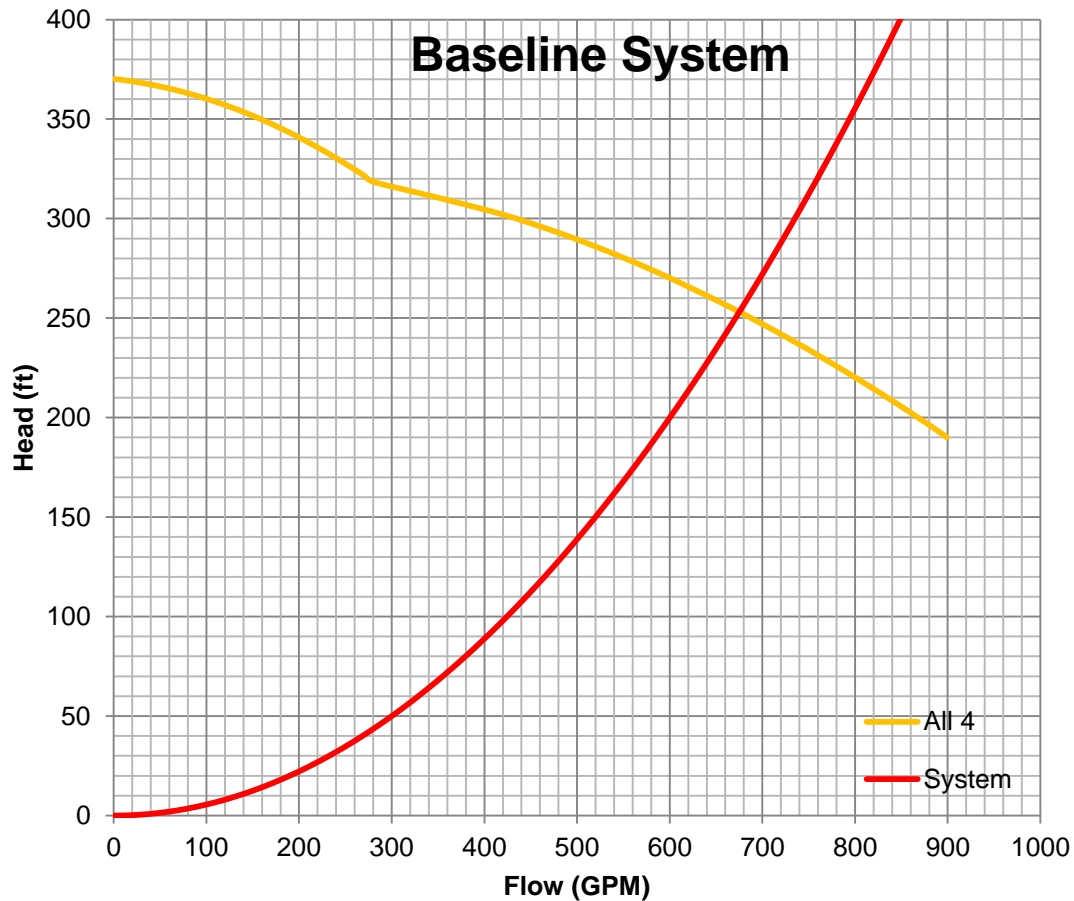

Process Cooling Circulation

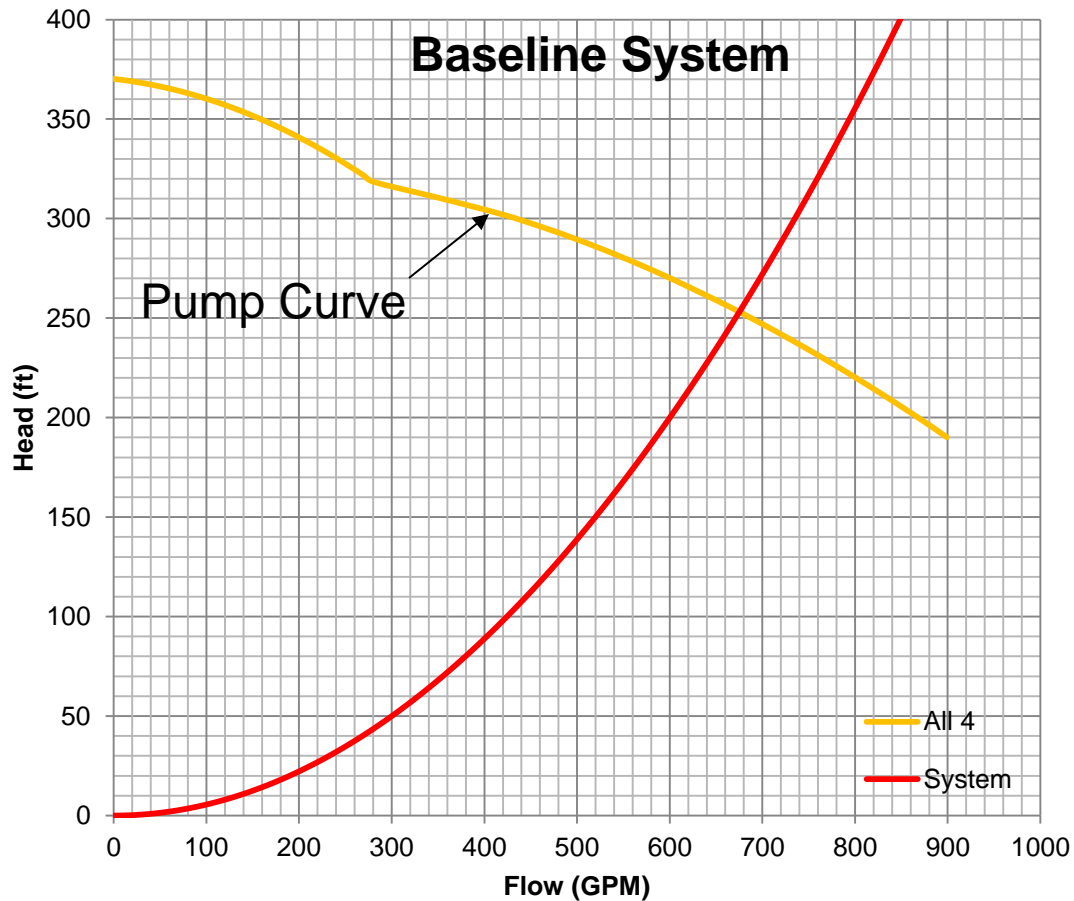

Process Cooling Circulation

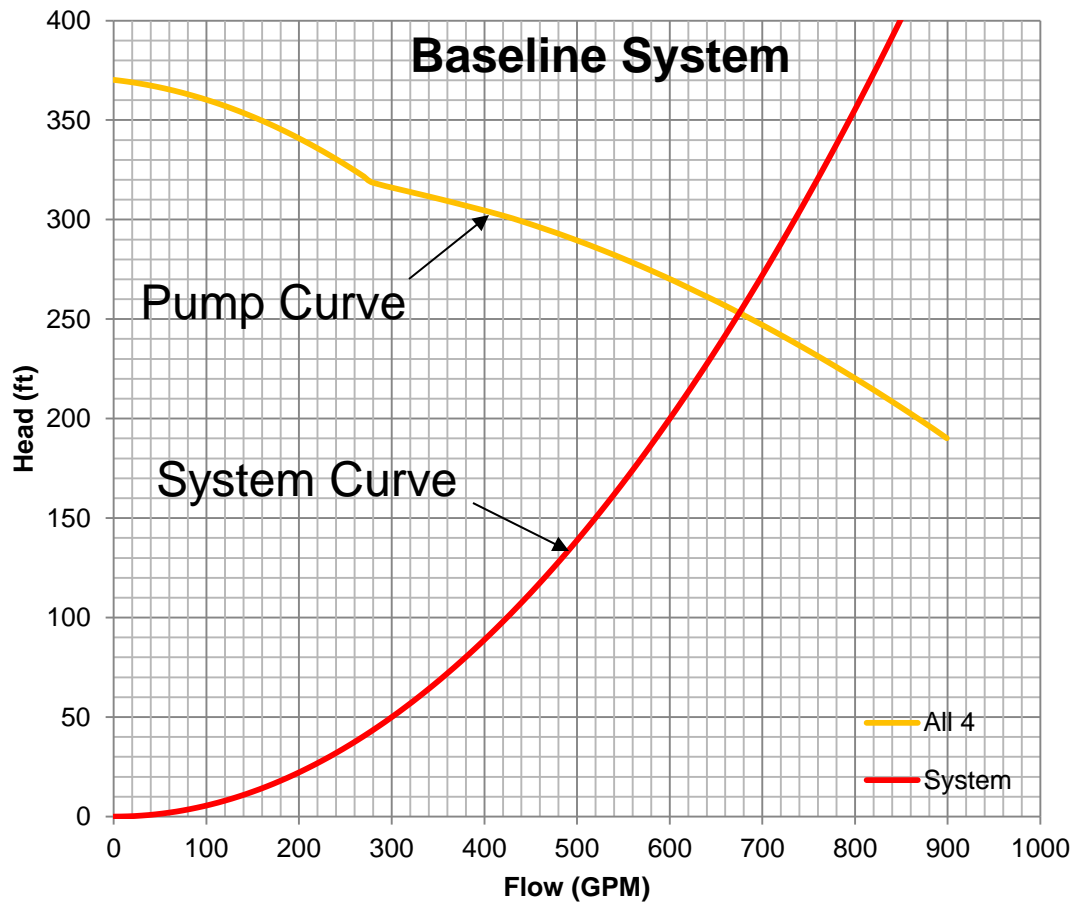

Process Cooling Circulation

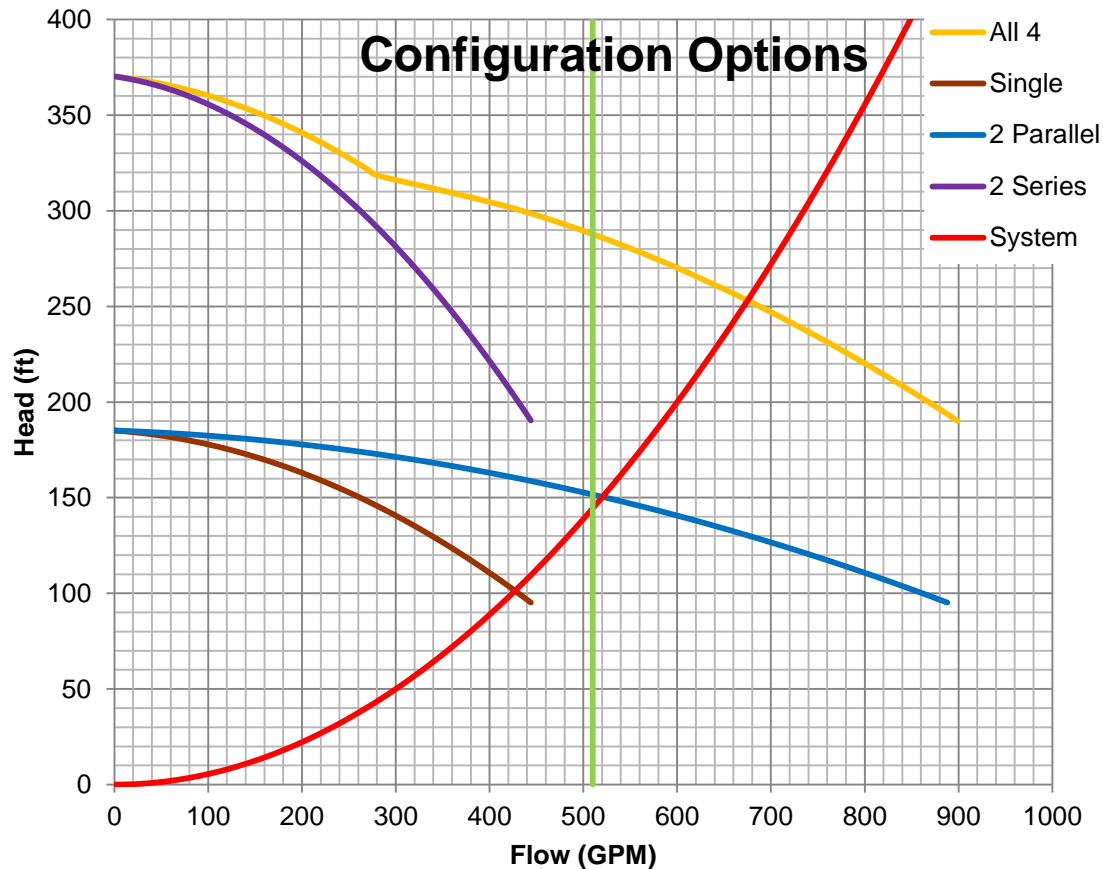

Process Cooling Circulation

- Reduce 2 Pumps

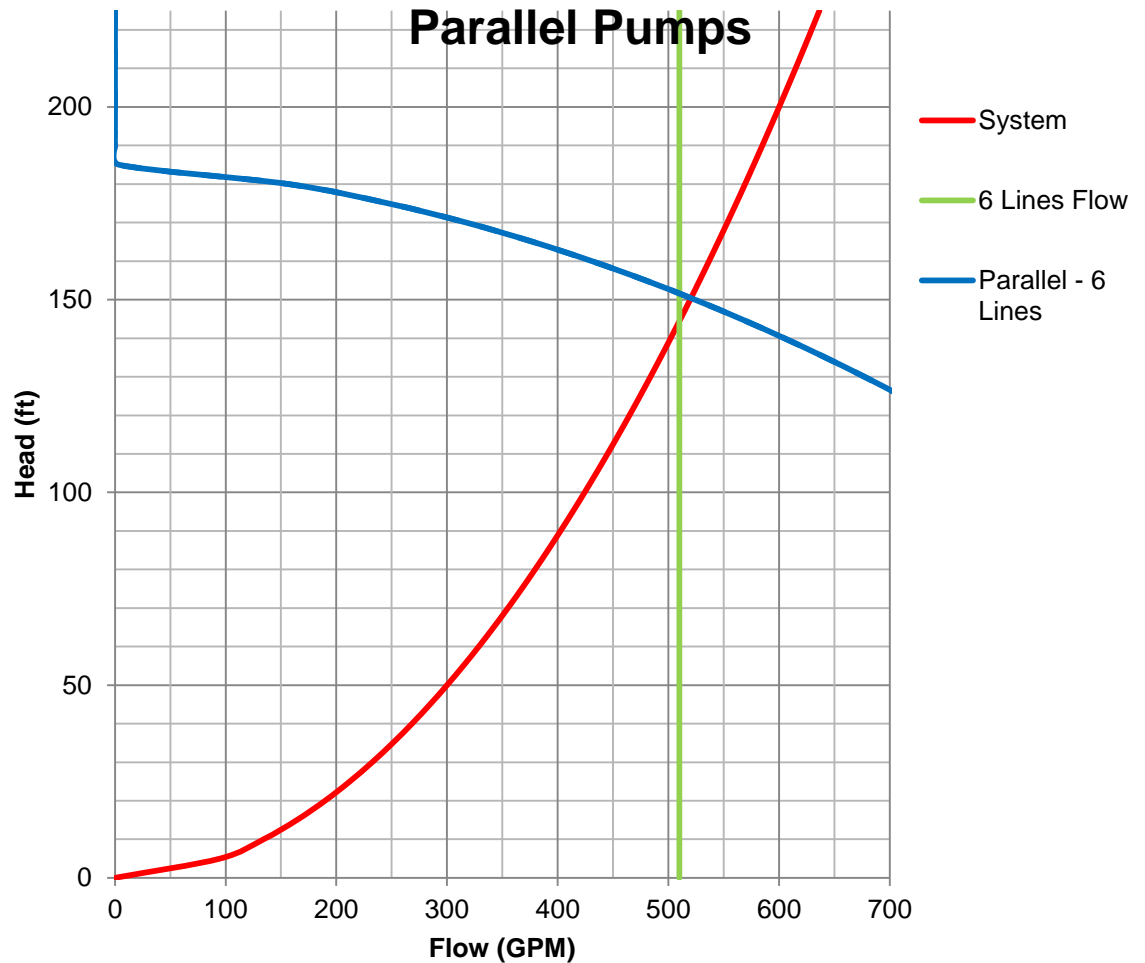

Process Cooling Circulation

- Reduce 2 Pumps

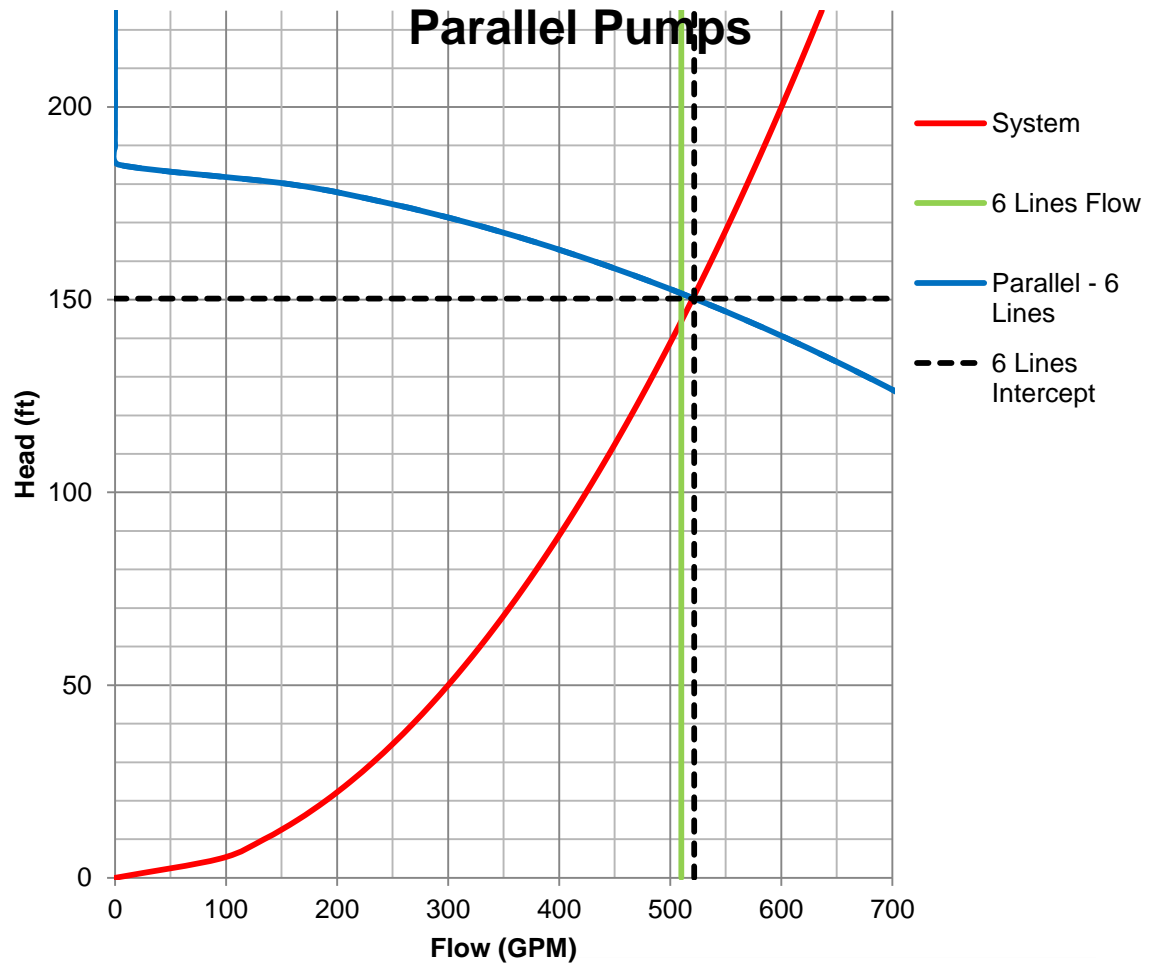

Process Cooling Circulation

- Reduce 2 Pumps
 - \$12,300/yr.

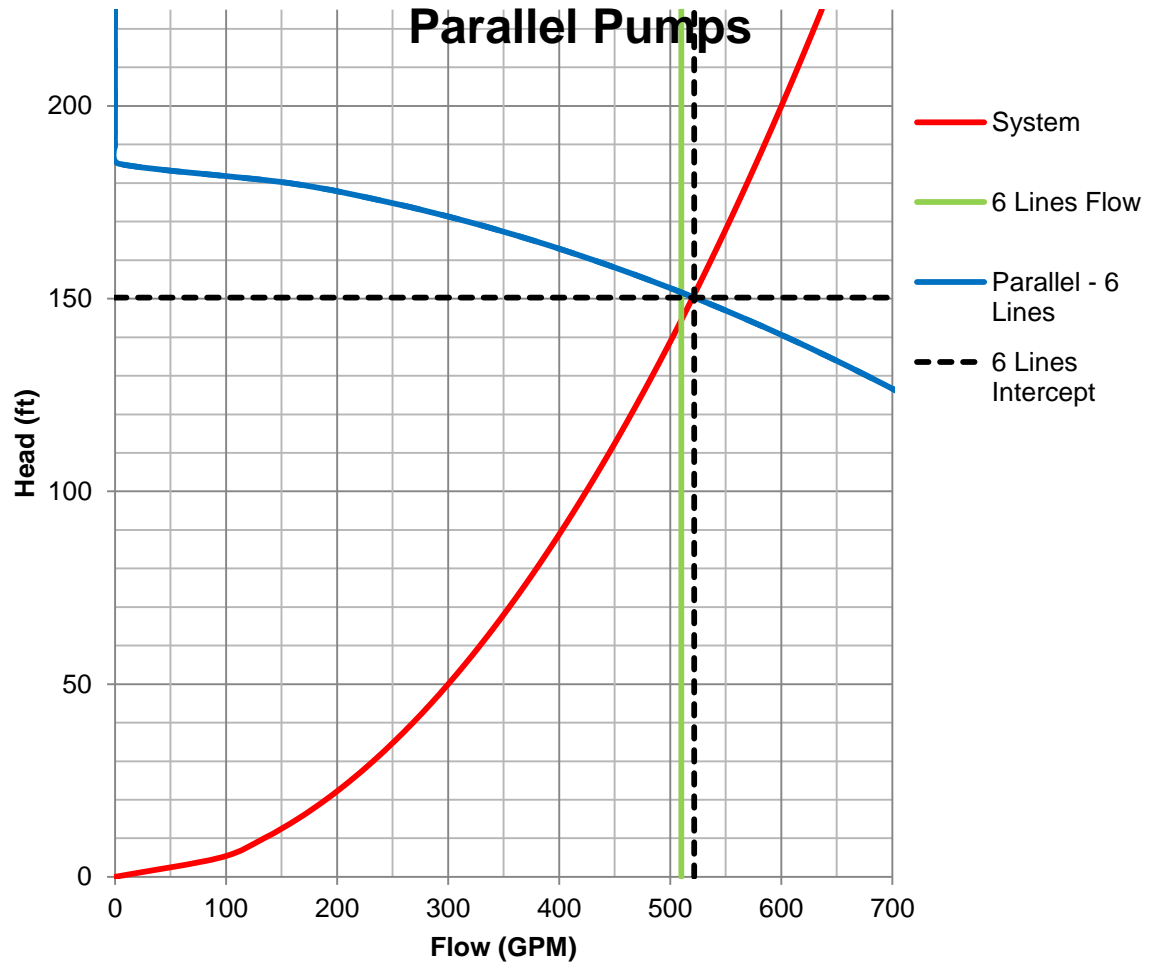

Process Cooling Circulation

- Reduce 2 Pumps
 - \$12,300/yr.
- Install VFDs

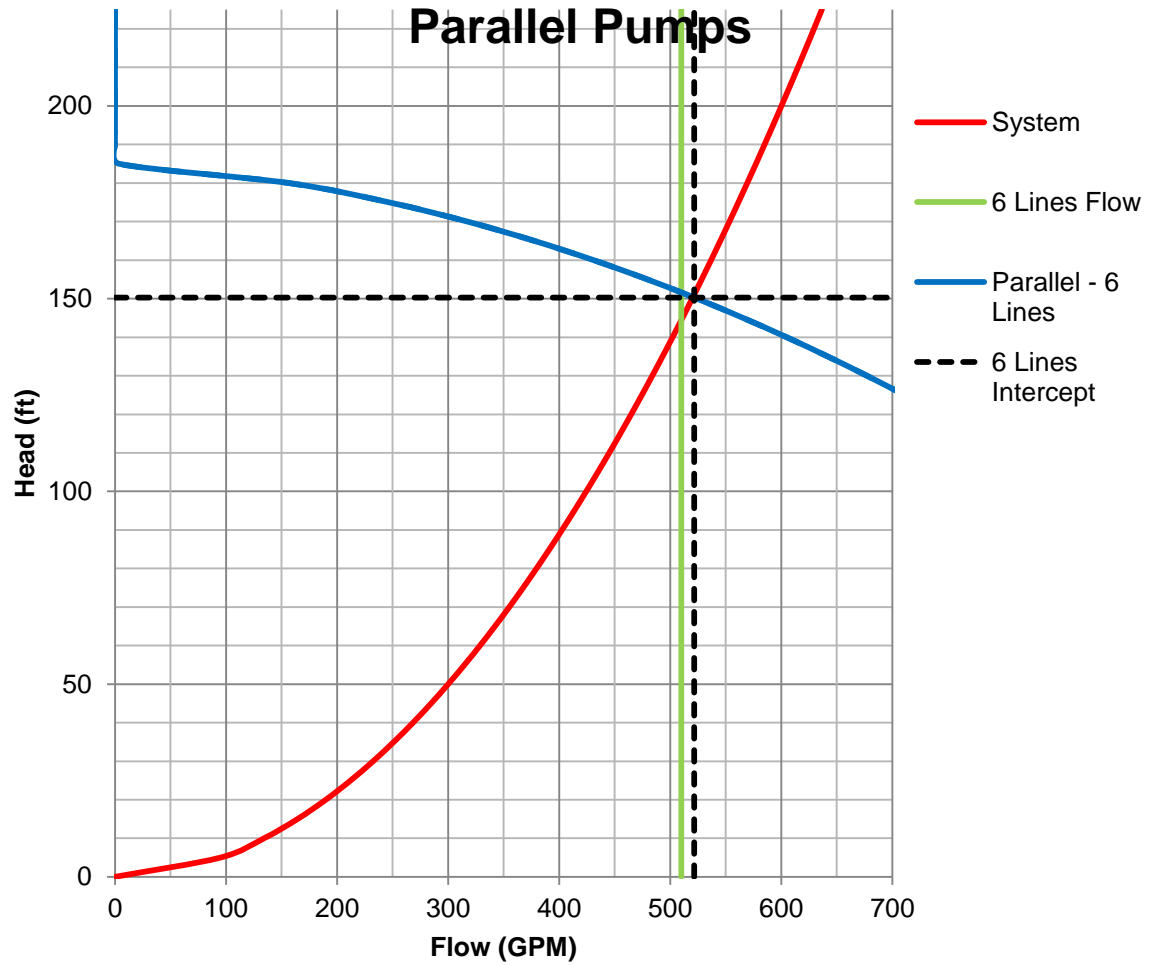

Process Cooling Circulation

- Reduce 2 Pumps
 - \$12,300/yr.
- Install VFDs

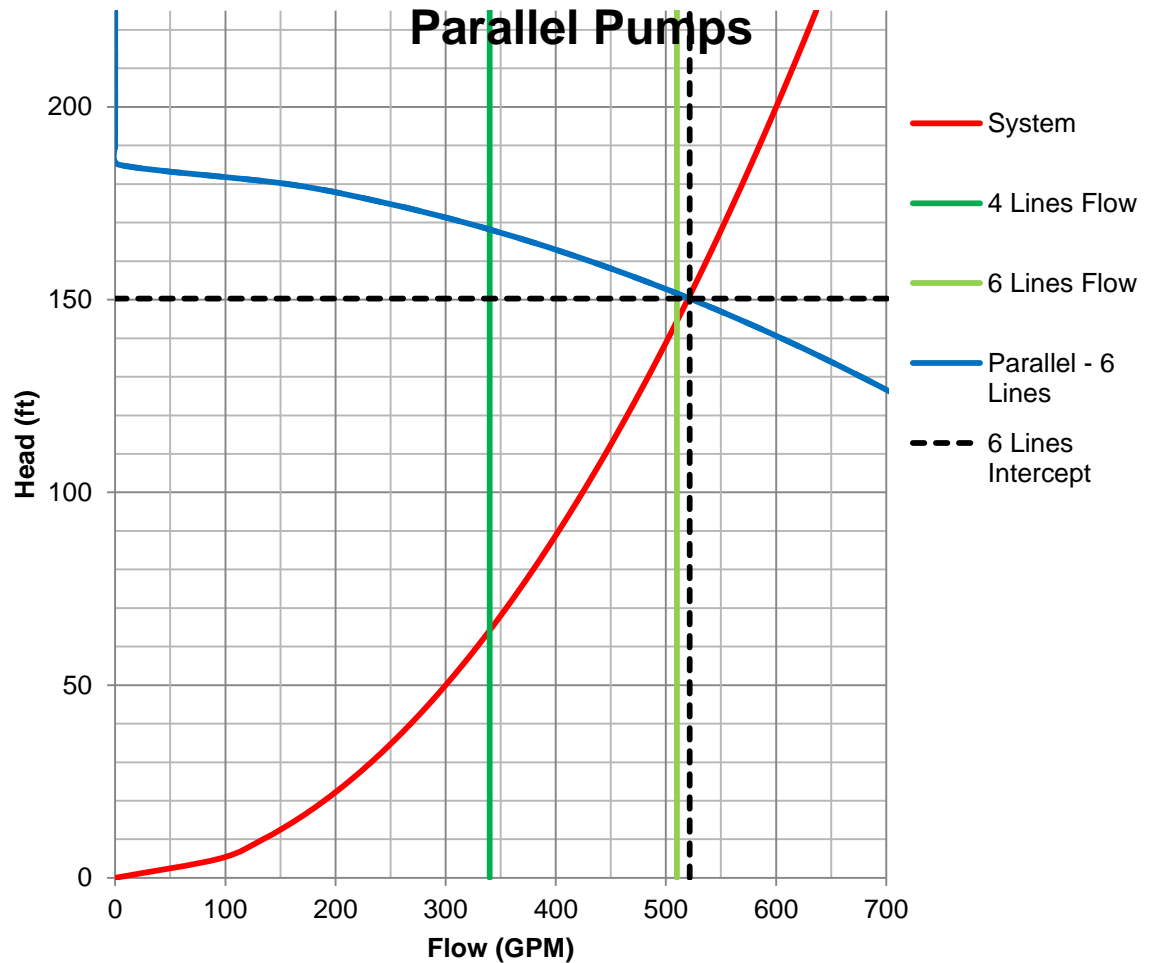

Process Cooling Circulation

- Reduce 2 Pumps
 - \$12,300/yr.
- Install VFDs

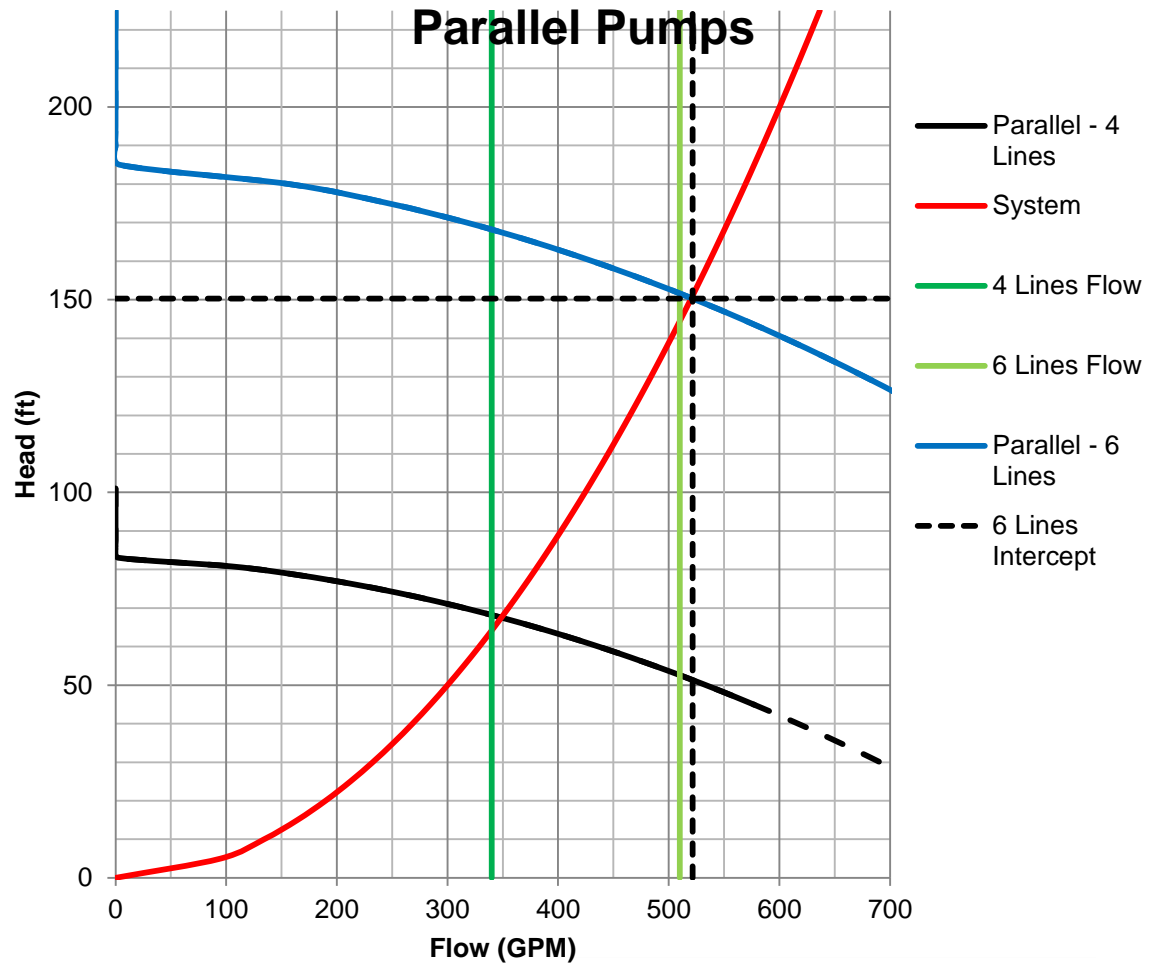

Process Cooling Circulation

- Reduce 2 Pumps
 - \$12,300/yr.
- Install VFDs

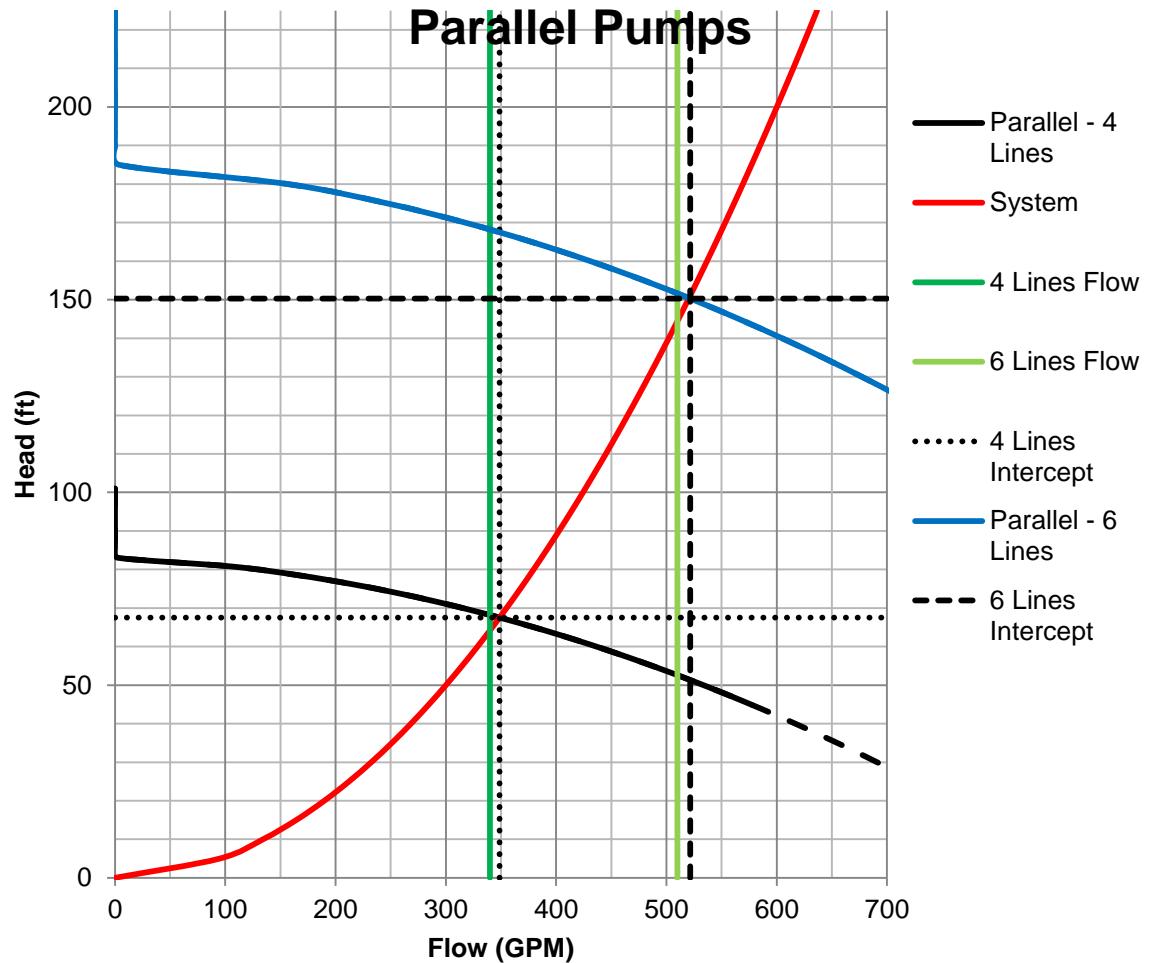

Process Cooling Circulation

- Reduce 2 Pumps
 - \$12,300/yr.
- Install VFDs
 - \$8,300/yr.

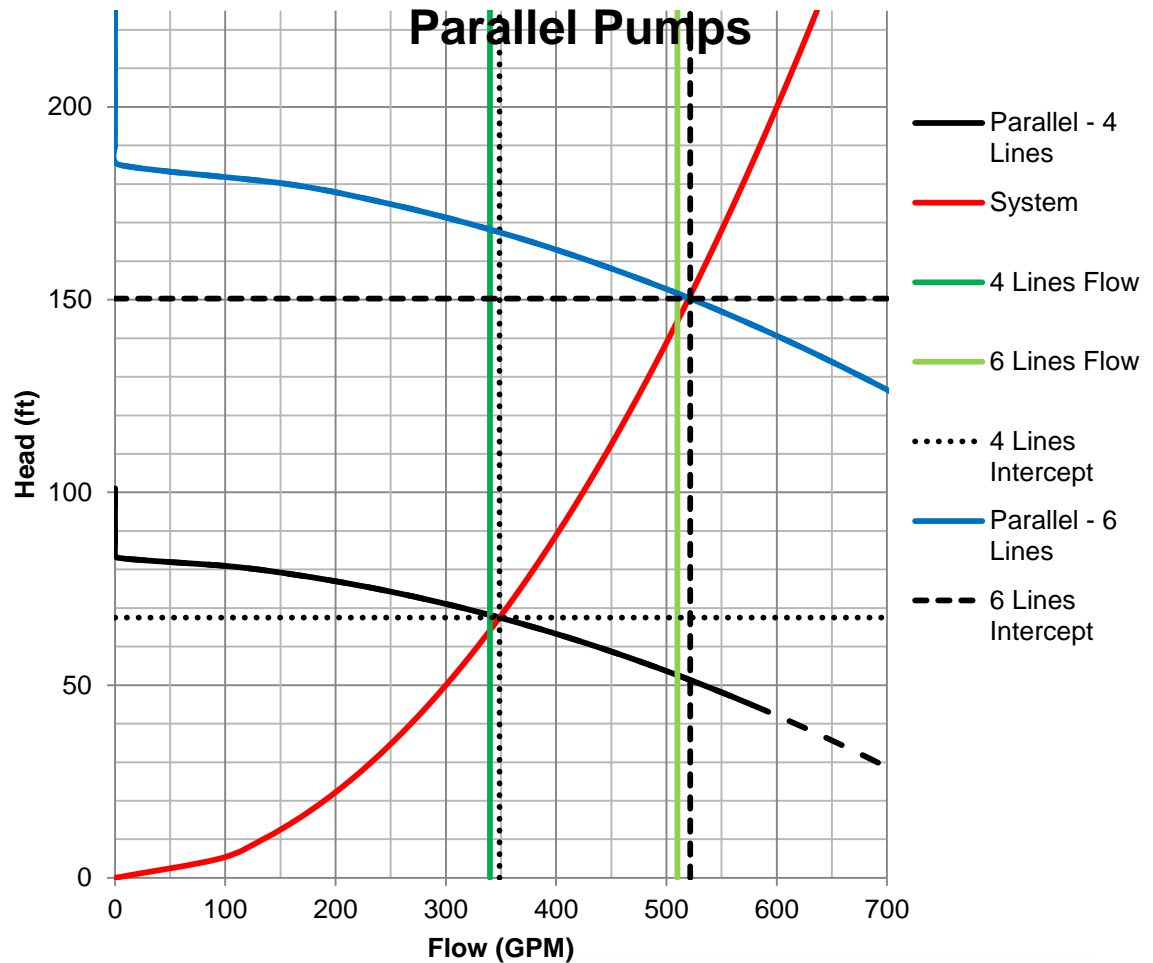

Grease Application

Condition	Material	Cost	Savings
Baseline	14,000 lb.	\$27,400	-

Grease Application

Condition	Material	Cost	Savings
Baseline	14,000 lb.	\$27,400	-



Grease Application

Condition	Material	Cost	Savings
Baseline	14,000 lb.	\$27,400	-
50% Rate	8,300 lb.	\$16,300	\$11,100



Grease Application

Condition	Material	Cost	Savings
Baseline	14,000 lb.	\$27,400	-
50% Rate	8,300 lb.	\$16,300	\$11,100
33% Rate	5,500 lb.	\$10,800	\$16,600



Other Projects



Cooling Tower Fans

- Disable two



Air Compressor

- Add tank



Natural Gas

- Unfeasible



Warehouse Fans

- Unfeasible

Summary

Recommendation	Waste/ energy reduced	Cost	Net Savings	Payback Period	Status
Process cooling pumps	242,400 kWh/yr.	\$1,490	\$20,600/ yr.	<1 month	considering contractor's proposal
Cooling Tower Fans	6,520 kWh/yr.	N/A	\$600/yr.	immediate	implemented
Grease Rate	5,700 lb.+/yr.	N/A	\$11,200+/yr	immediate	pending test results

Personal Benefits

- Application of knowledge
- Real-world experience
- New processes and equipment
- Technical communication

Questions?